



Competitive Crusher Pulverizing Mill for 0-1mm Coal Output Size

Our Product Introduction

more products please visit us on mining-crushermachine.com

Basic Information

- Place of Origin: Zhengzhou, China
- Brand Name: Ascend
- Certification: ISO9001, CE
- Model Number: PC400x300 PC600x400 PC800x600 PC1000x800
- Minimum Order Quantity: 1 set
- Price: negotiable
- Packaging Details: 1. Standard parts packed in the wooden cases. 2. Big parts packed by plastic membrane. 3. The whole machine is loaded in the container.
- Delivery Time: 7-10 working days
- Payment Terms: L/C, T/T, Western Union, MoneyGram
- Supply Ability: 100 sets per month



Product Specification

- Product Category: Hammer Mill Crusher
- Contact Information: Available
- Target Market: Kenya, Zimbabwe, Dr Congo
- Advantages: Simple Structure, High Grinding Rate, High Production Efficiency
- Warranty Period: 1 Year
- Final Products: Gravel, Limestone, Coal
- Output Capacity: 3-8tph
- Product Name: PC400x300 Small Capacity 3-8tph Output Size 0-1mm Gravel Limestone Coal Hammer Crusher For Kenya Zimbabwe Dr Congo Marke
- Highlight: **0-1mm Coal Crusher Pulverizing Mill, Competitive Crusher Pulverizing Mill,**

Product Description:

The Crushing Hammer Mill Machine, also known as the Hammer Crushing Pulverizing Mill, is a Stone Crashing Machine designed to crush medium-hard materials. It is perfect for gravel, limestone, and coal crushing, producing final products with sizes as small as 0-1mm. The PC400x300 small capacity 3-8tph output size 0-1mm gravel limestone coal hammer crusher is an excellent choice for customers in Kenya, Zimbabwe, and Dr. Congo market.

With a 1-year warranty period, you can be confident that this Hammer Crushing Pulverizing Mill is built to last. It has a small capacity, making it perfect for small-scale crushing operations. Its output size is suitable for various industrial applications, such as road construction, building, and cement manufacturing.

The Hammer Crushing Pulverizing Mill is easy to operate and maintain. It is designed with safety features to prevent any accidents in the crushing process. Its compact design makes it easy to transport and install, allowing you to set it up quickly and start crushing immediately.

If you are looking for a reliable and efficient Hammer Crushing Pulverizing Mill, the PC400x300 small capacity 3-8tph output size 0-1mm gravel limestone coal hammer crusher is the perfect choice. Its versatility and durability make it an excellent investment for your crushing needs.

Features:

Product Name: PC400x300 small capacity 3-8tph output size 0-1mm gravel limestone coal hammer crusher for Kenya Zimbabwe Dr Congo marke

Output Capacity: 3-8tph

Product Category: Hammer Mill Crusher

Working Principle: The motor drives the rotor to rotate at a high speed through the belt, and on the rotor there are series of hammers. When the material get into the working area of hammers, the rotating hammers with high rotation speed are crushing the material, the crushed product meeting the required size can be discharged by the outlet and become the final products, the large size product are brought back to the crushing area by the hammers for being re-crushed until they reached the required size.

Output Size: 0-1mm

Features: Grinding Crusher Pulverizing Mill, Crushing Mill Pulverizer Machine, Crusher Pulverizing Mill

Technical Parameters:

Product Name:	PC400x300 small capacity 3-8tph output size 0-1mm gravel limestone coal hammer crusher for Kenya Zimbabwe Dr Congo market
Advantages:	Simple structure, high grinding rate, high production efficiency
Working Principle:	The motor drives the rotor to rotate at a high speed through the belt, and on the rotor there are series of hammers. When the material get into the working area of hammers, the rotating hammers with high rotation speed are crushing the material, the crushed product meeting the required size can be discharged by the outlet and become the final products, the large size product are brought back to the crushing area by the hammers for being re-crushed until they reached the required size.
Contact Information:	Available
Warranty Period:	1 Year

Adjustability:	Can adjust the grate strip gap according to user requirements and change the material particle size
Final Products:	Gravel, limestone, coal
Applicable Industry:	Energy&Mining
Material:	Limestone, coke, coal, etc.
Target Market:	Kenya, Zimbabwe, Dr Congo

Keywords: Hammer Crushing Pulverizing Mill, Crushing Hammer Mill Machine, Pulverizing Hammer Mill

Applications:

The Ascend Hammer Mill Crusher, available in models PC400x300, PC600x400, PC800x600, and PC1000x800, is a versatile and efficient tool for grinding, pulverizing, and crushing various materials. It is suitable for both dry and wet grinding conditions and is ideal for use in various industries, including mining, cement, coal, metallurgy, building materials, road construction, and chemical engineering. This Hammer Grinder Pulverizer features a simple structure and high grinding rate, ensuring high production efficiency. It is equipped with a series of hammers that rotate at a high speed, crushing the material that gets into the working area of the hammers. The crushed product that meets the required size can be discharged by the outlet and become the final product. Large size products are brought back to the crushing area by the hammers for re-crushing until they reach the required size.

The Grinding Crusher Pulverizing Mill has been certified with ISO9001 and CE, ensuring that it meets international standards. It is manufactured in Zhengzhou, China, and has a minimum order quantity of 1 set. The price is negotiable, and the Hammer Crushing Pulverizing Mill can be paid for using L/C, T/T, Western Union, or MoneyGram. It has a supply ability of 100 sets per month and can be delivered within 7-10 working days. The packaging details include standard parts packed in wooden cases, big parts packed by plastic membrane, and the whole machine loaded in the container.

The Ascend Hammer Mill Crusher is ideal for use in various scenarios, including:

Mining: It can be used for crushing various minerals, including coal, limestone, gypsum, and more.

Cement: It can grind raw materials and clinkers, making it ideal for use in cement production.

Metallurgy: It can be used for grinding various metals, including iron, gold, and silver.

Building Materials: It can grind materials such as sand, gravel, and stones, making it suitable for use in road construction and building projects.

Chemical Engineering: It can be used for grinding various chemical materials, including fertilizers, pesticides, and more.

The Hammer Grinder Pulverizer is especially suited for use in the target markets of Kenya, Zimbabwe, and Dr Congo. It comes with a 1-year warranty period, ensuring that customers can be confident in their purchase of this Grinding Crusher Pulverizing Mill.

Support and Services:

The Hammer Mill Crusher product is designed to provide technical support and services to ensure optimal performance and longevity of the equipment. Our team of experts is available to offer guidance on installation, operation, and maintenance of the product. We also provide troubleshooting services to address any issues that may arise during operation. Additionally, we offer training programs to educate users on the proper use and handling of the equipment. Our goal is to ensure that our customers receive the highest level of support and service throughout the lifetime of their Hammer Mill Crusher.

Packing and Shipping:

1. The Hammer Mill Crusher product will be packaged in a sturdy cardboard box to ensure safe transportation.
2. The product will be wrapped in bubble wrap to prevent any damage during shipping.
3. The box will be labeled with the product name, model number, and shipping address.

Shipping:

1. The Hammer Mill Crusher product will be shipped via a reliable courier service.
2. The shipping cost will be calculated based on the weight and destination of the package.
3. The estimated shipping time will be provided to the customer upon checkout.

FAQ:

Here are some frequently asked questions about Ascend Hammer Mill Crusher:

Q: What is the brand name of this product?

A: The brand name of this product is Ascend.

Q: What are the available models of the Hammer Mill Crusher?

A: The available models of the Hammer Mill Crusher are PC400x300, PC600x400, PC800x600, and PC1000x800.

Q: What certifications does this product have?

A: This product has ISO9001 and CE certifications.

Q: Where is this product made?

A: This product is made in Zhengzhou, China.

Q: What is the minimum order quantity for this product?

A: The minimum order quantity for this product is 1 set.

Q: Is the price negotiable?

A: Yes, the price is negotiable.

Q: What are the available payment terms?

A: The available payment terms are L/C, T/T, Western Union, and MoneyGram.

Q: How many sets can be supplied per month?

A: 100 sets can be supplied per month.

Q: What is the delivery time for this product?

A: The delivery time for this product is 7-10 working days.

Q: How is the product packaged?

A: The product is packaged with standard parts packed in the wooden cases, big parts packed by plastic membrane, and the whole machine loaded in the container.





1. 上机体 Upper Body
2. 篦条板 Grate Plate
3. 锤盘 Middle Dody
4. 出料口 Discharging Mouth
5. 锤头 Hammer
6. 侧衬板 Side Plate
7. 下机体 Lower Body
8. 支座 Stand
9. 电机 Motor
10. 传动轴 Transmission Axle
11. 锤头轴 Hammer Axle
12. 入料口挡板 Liner at Feeding Mouth
13. 衬板 Liner

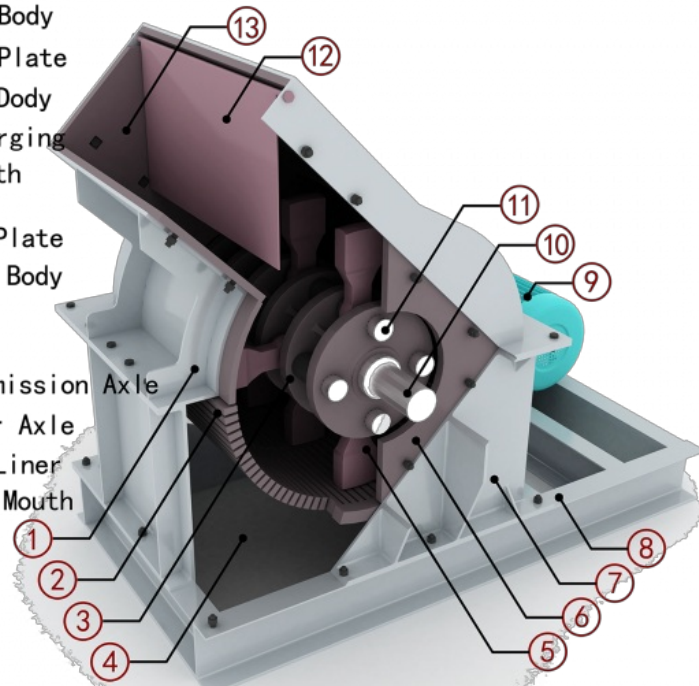

Model	Input size(mm)	Output size(mm)	Capacity(t/h)	Power(kw)	Weight(kg)
PC400×300	≤100	≤10	5-10	11	800
PC600×400	≤120	≤15	10-25	18.5	1500
PC800×600	≤120	≤15	20-35	55	3100
PC1000×800	≤200	≤13	20-40	115	7900
PC1000×1000	≤200	≤15	30-80	132	8650
PCX1300×1200	≤250	≤19	80-200	240	13600



Contact: Wilson
Mobile(WhatsApp/Wechat): +86-18221130967
Email: wilson_ascendme@163.com



Wechat



WhatsApp



ASCEND Henan Ascend Machinery Equipment Co., Ltd.

+86 18221130967

wilson_ascendme@163.com

mining-crushermachine.com

